

*Capresso*

**infinity**

CONICAL Burr  
Grinder



Model #565  
#560

- **Instructions**
- **Warranty**
- **Product Registration**

100W / 120V~ / 60 Hz

# IMPORTANT SAFEGUARDS

When using electrical appliances, basic safety precautions should always be followed, including the following:

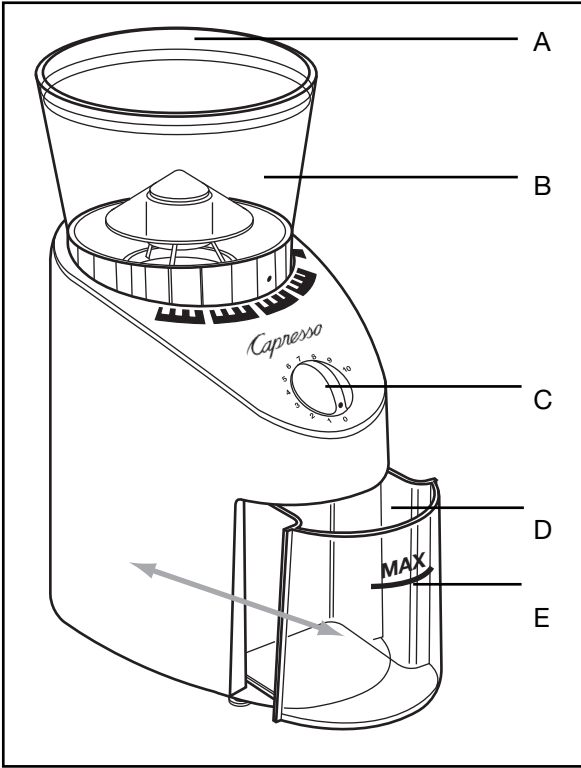
1. Read all instructions.
2. Do not touch hot surfaces. Use handles or knobs.
3. To protect against fire, electric shock and injury to persons, do not immerse cord, plugs, or body of machine in water or other liquid.
4. Close supervision is necessary when any appliance is used by or near children.
5. Unplug from outlet when not in use and before cleaning. Allow to cool before putting on or taking off parts, and before cleaning the appliance.
6. Do not operate any appliance with a damaged cord or plug or after the appliance malfunctions, or has been damaged in any manner. Return appliance to the nearest authorized service facility for examination, repair, or adjustment.
7. The use of accessory attachments not recommended by the appliance manufacturer may result in fire, electric shock, or injury to persons.
8. Do not use outdoors.
9. Do not let the cord hang over the edge of a table or counter, or touch hot surfaces.
10. Do not place on or near a hot gas or electric burner, or in a heated oven.
11. Always attach plug to appliance first, then plug cord into the wall outlet. To disconnect, turn any control to "OFF," then remove plug from wall outlet.
12. Do not use this appliance for other than intended use.
13. Check bean container (B) for presence of foreign objects before using.
14. To prevent clogging and overheating of motor, never grind above the "Max-Line" of the ground coffee container (Fig. 1, E).

## SAVE THESE INSTRUCTIONS SPECIAL CORD SET INSTRUCTIONS

Regarding your Cord Set:

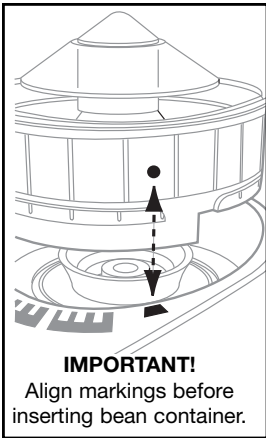
- A.** A short power-supply cord (or detachable power-supply cord) is to be provided to reduce risks resulting from becoming entangled in or tripping over a longer cord.
- B.** Longer detachable power-supply cords or extension cords are available and may be used if care is exercised in their use.
- C.** If a long detachable power-supply cord or extension cord is used, (1) the marked electrical rating of the detachable power-supply cord or extension cord should be at least as great as the electrical rating of the appliance, (2) if the appliance is of the grounded type, the extension cord should be a grounding type 3-wire cord, and (3) the longer cord should be arranged so that it will not drape over the counter top or table top where it can be pulled on by children or tripped over.
- D.** This appliance has a polarized plug (one blade is wider than the other). As a safety feature, this plug will fit in a polarized outlet only one way. If the plug does not fit fully in the outlet, reverse the plug. If it still does not fit, contact a qualified electrician. Do not attempt to defeat this safety feature.

**NOTICE: For Model# 565 only:** Your Infinity with metal housing has a 3-prong grounded plug. To reduce the risk of electrical shock this plug will fit in an outlet only one way. If the plug does not fit in the outlet contact a qualified electrician. DO NOT modify the plug in any way.

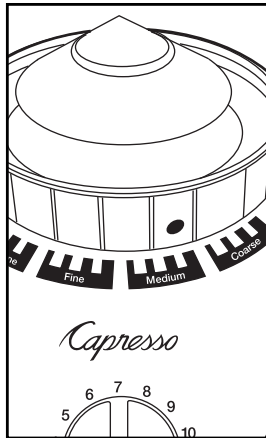


**Fig. 1**

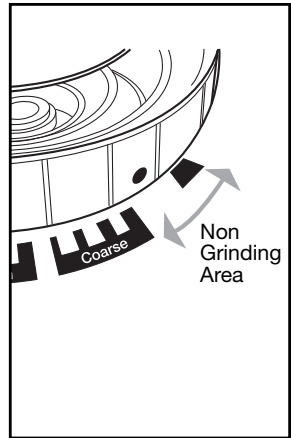
- A Bean Container Lid
- B Bean Container
- C Timer On-Switch
- D Ground Coffee Container
- E Max Line for Ground Coffee



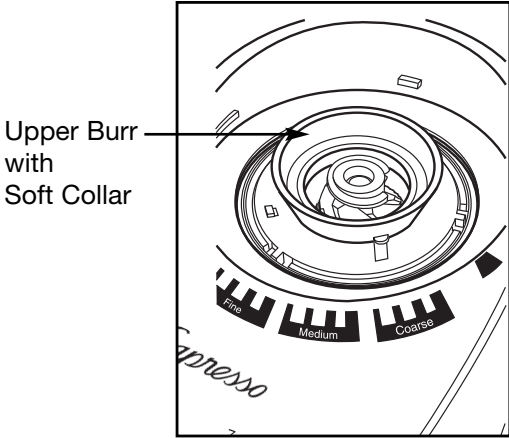
**Fig. 2**



**Fig. 3**

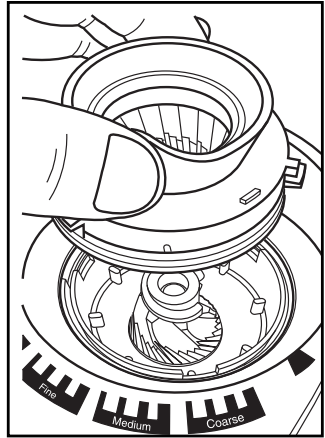


**Fig. 3a**

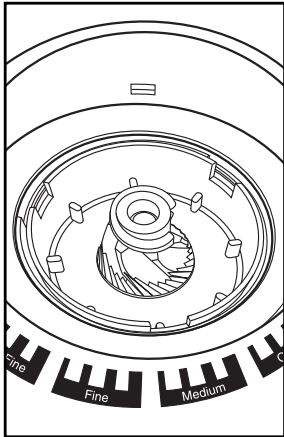


Upper Burr  
with  
Soft Collar

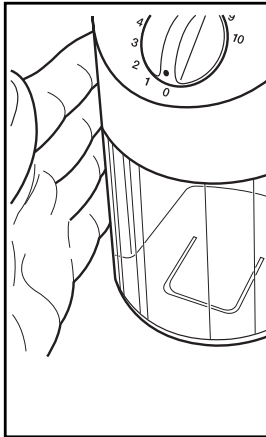
**Fig. 4**



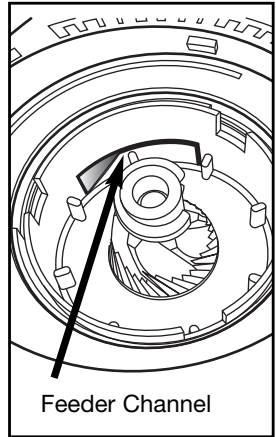
**Fig. 5**



**Fig. 6**



**Fig. 7**



Feeder Channel

**Fig. 8**

**CUSTOMER SERVICE**

Thank you for choosing this Capresso product. Please study these instructions carefully before using your new grinder. For further information please call:

**1-800-767-3554**

**Monday-Thursday 8AM to 9PM,**

**Friday 8AM to 8PM and Saturday 9AM to 5PM Eastern Time Zone.**

If you call at any other time please leave a message with your telephone number and when we can call you back. You can also send us a

**FAX at: 201-767-9684 or EMAIL us at [contact@capresso.com](mailto:contact@capresso.com)**

## 1. WELCOME

This Burr Grinder uses solid steel conical burrs and a high reduction motor to grind slowly and precisely from Turkish fine to French Press coarse. The slow grinding imparts minimal heat on the coffee thus preserving maximum aroma. The safety lock mechanism prevents the grinder from grinding without the bean container in place. The removable upper burr makes cleaning easy. We are sure you will find the right fineness setting for your coffee application. Enjoy!

## 2. BEFORE INITIAL USE

1. Carefully unpack your grinder and remove all packaging material.
2. Wipe the base, lid and containers with a dry, clean cloth.
3. Lift the upper burr (Fig. 5) and check if the grinding chamber is free of any foreign objects (Fig. 6).
4. Replace the upper burr. Make sure the soft plastic collar of the upper burr is in place (Fig. 4)
5. Insert the bean container into the machine (Fig. 2).
6. Place the lid (Fig. 1, A) onto the bean container before turning it to the desired position. It is easier to turn the bean container back and forth with the lid in place.
7. Initially only fill a few scoops of coffee beans into the grinder.

**Not Dishwasher Safe:** The removable upper burr and the soft collar are not dishwasher safe.

**Dishwasher Safe:** (top rack only, away from the heating element):  
The bean container, the lid, the ground coffee container.

## 3. HELPFUL HINTS

1. Never grind without the ground coffee container in place! Make sure that the ground coffee container is completely inserted into the machine before grinding. Otherwise ground coffee can blow out of the grinder spout creating a mess on your countertop.
2. Make sure there are no beans in the bean container before removing it from the machine.
3. When grinding different kinds of beans, only fill the bean container with the amount you intend to grind. This way you avoid emptying the bean container.
4. If you need to empty the bean container proceed as follows:
  - a. Unplug the item,
  - b. Turn the machine upside down
  - c. Carefully pour the beans into another receptacle.
5. The finer the grind setting the longer it takes to grind a certain amount of coffee, e.g. in a very coarse setting the machine will grind more coffee in 20 seconds than in a very fine setting.

6. When grinding in the two or three finest settings (for Turkish coffee) only fill a few scoops of coffee beans into the bean container and check if the ground coffee passes through into the ground coffee container. After grinding in the finest settings we highly recommend cleaning the grinding chamber (Fig. 6) before next use.
7. **Please note:** Never grind "in advance". Only grind the amount of coffee you will use for preparing coffee within the next hour. Ground coffee loses aroma and flavor very fast. Ground coffee also attracts other odors.
8. Do NOT grind for more than three minutes in a row. All the parts will get warm which will influence the aroma of your coffee.
9. **Important:** Never let ground coffee exceed the Max-Line on the ground coffee container (Fig. 1,E). Too much coffee in the ground coffee container can back-up into the feeder channel. If grinding continues this can burn out the motor.
10. Before removing the ground coffee container, tap the machine a few times (Fig. 7). This will relieve some of the static build-up which occurs when grinding.

#### 4. GRINDING

1. Grinder only grinds with the bean container in place and the dot on the bean container pointing to one of the fineness settings (Fig. 3).
2. Between the insertion marking and the coarsest setting (Fig. 3a) the grinder will not grind.
3. When the bean container points to one of the grind settings, turn the timer (Fig. 1,C) to any position and grinding will start.

#### **Stopping the grinding action:**

When the timer reaches the 0-position the machine will stop grinding.

- You can also interrupt grinding by turning the bean container to the right (counter clockwise) beyond the coarsest setting (Fig. 3a). This will stop the grinding action. The timer will still run until it stops in the 0-position.
- This manual stopping option can come in handy if you turned the timer too much or if a foreign object (stone etc.) blocks the burrs.

#### 5. GRIND SETTINGS

There are a total of 16 grind settings. They are subdivided into 4 settings each for COARSE, MEDIUM, FINE and EXTRA FINE. We are confident that you will find the proper setting for your coffee preparation. Our general recommendations are:

#### **COARSE**

- French Press Coffee Makers.
- Percolators.

**MEDIUM:**

- Steam Boiler Espresso Machines.
- Drip Coffee Makers. When using GoldTone Filters use a somewhat coarser setting; when using Filter Paper try a finer setting.

**FINE:**

- Espresso pump machines.
- Fully Automatic Coffee Centers (when using ground coffee).
- Stovetop Mocha Machines.
- Manual filters with manual brewing.

**EXTRA FINE:**

- Some espresso pump machines.
- Manual preparation of Turkish coffee (two finest settings).

***Helpful Hints:***

- For espresso pump machines and automatic coffee centers: If your coffee or espresso brews too fast, try finer settings. If your espresso brews too slow, try coarser settings.
- For French Press: Please follow the instructions of your French Press coffee maker (after pouring water over the ground coffee, stir thoroughly to prevent the ground coffee from clogging).
- Dark, oily beans: Grind dark oily beans one or two steps coarser than medium or light brown beans. In the finest settings it is possible that oil residue of dark, oily beans clog the feeder channel (See chapter 6 CLEANING).
- Clogging and Overflow: If your coffee making equipment cannot process the water through the grounds, overflow or clogging might occur. Choose a coarser grind setting.

**6. CLEANING**

1. Always unplug the grinder before cleaning.
2. Coffee oils can deposit inside the grinding chamber and become rancid. Clean the grinding chamber daily (Fig. 6).
3. Clean the upper and lower burr with the brush.
4. Check the feeder channel (Fig. 8) for coffee build up and use the small brush to push any build up into the ground coffee container.
5. Wipe housing with a soft damp cloth and make sure that all parts are completely dry before next use.

**Important:** Never pour water or any other liquid into the grinder.

**Please note:** Dark oily beans require you to clean the grinding chamber more often than medium brown non-oily beans.

## **7. LIMITED WARRANTY**

This warranty covers your Capresso Infinity Burr Grinder (Model #560 and #565). This warranty is in effect for one year from the date of the first consumer purchase. **This warranty covers all defects in materials or workmanship (parts and labor).**

### **This warranty does not cover:**

- Any machine not purchased from an Authorized Dealer.
- Damage caused by accident, abuse, negligence, misuse, improper operation or failure to follow instructions contained in this manual.
- Any service or alteration performed by an unauthorized person, company or association.
- Damage caused by neglecting and omitting cleaning.
- Damage caused by use of instant coffee or any other ingredients not allowed in this product.
- Any used machines bought at auctions and unauthorized websites.

### **Other limitations and exclusions:**

Any implied warranties including fitness for use and merchantability are limited in duration to the period of the express warranty set forth above and no person is authorized to assume for JURA any other liability in connection with the sale of the machine.

JURA expressly disclaims liability for incidental and consequential damages caused by the machine. The terms “incidental damages” refer to the loss of the original purchasers time, loss of the use of the machine or other costs relating to the care and custody of the machine. The terms “consequential damages” refer to the cost of repairing or replacing other property which is damaged when this machine does not work properly. The remedies provided under this warranty are exclusive and in lieu of all others. This warranty gives you specific legal rights, and you may also have other rights which vary from state to state.

## **JURA Inc.**

81 Ruckman Road, PO Box 775

Closter, NJ 07624

Tel: 800-767-3554

Fax: 201-767-9684

Email: [contact@capresso.com](mailto:contact@capresso.com)

Website: [www.capresso.com](http://www.capresso.com)